

GR-2

SUBMERSIBLE CIU GUIDE RAIL SYSTEMS

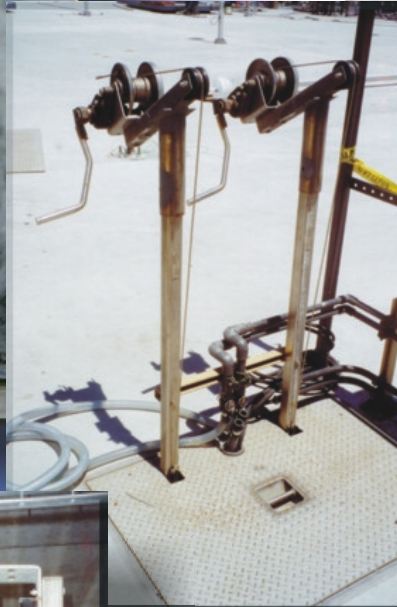

GR-2 GUIDE RAIL SYSTEMS

The GR-2 guide rails systems are designed for use with the GAS MASTRRR series submersible chemical induction units.

The guide rails are constructed from 316 stainless steel materials for long term duty in harsh water, wastewater, or CSO basin installations.

The dual rail system allows the motor slide bracket to easily lower and raise without binding and provides support for the CIU as it stops in a vertical, horizontal, or pivoting position.

The GR-2 rails are available with stand off support brackets for wide channels applications. Options include: Integral davit cranes, floor flange supports, and dual unit systems for side by side CIU applications.

The GAS MASTRRR series GR-2 rail systems are proudly made in the U.S.A. and are backed by a 1 year limited warranty.

THE MASTRRR COMPANY

www.gasmastrrr.com mastrrr@airmail.net
1-800-299-6836 1-800-226-2659 Fax



GR-2

SUBMERSIBLE CIU GUIDE RAIL SYSTEMS

GR-2 GUIDE RAIL SYSTEMS

TOP VIEW

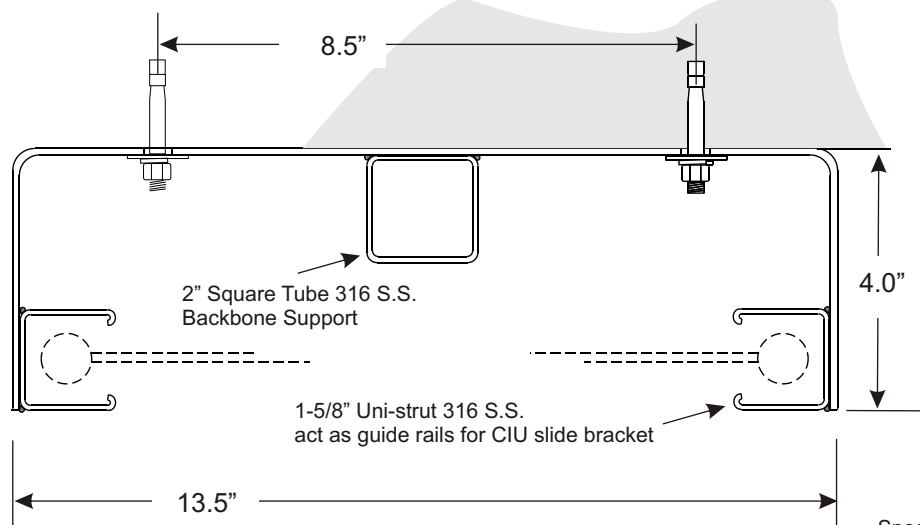

ISO VIEW

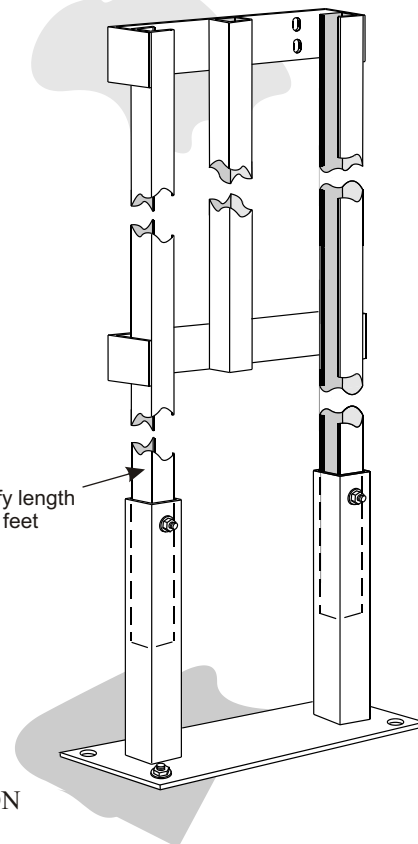

STANDARD FLOOR SUPPORT BASE

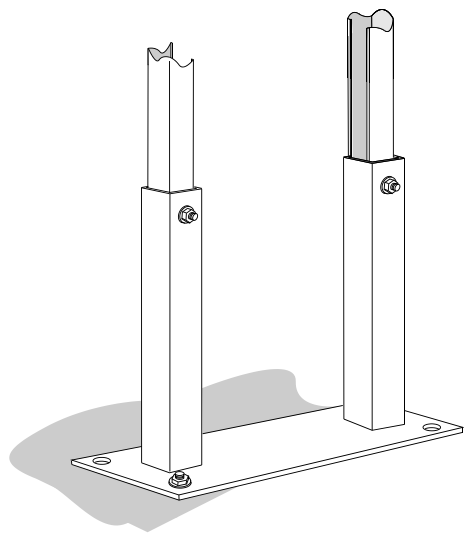

OPTIONAL WET INSTALLATION FLOOR SUPPORT BASE

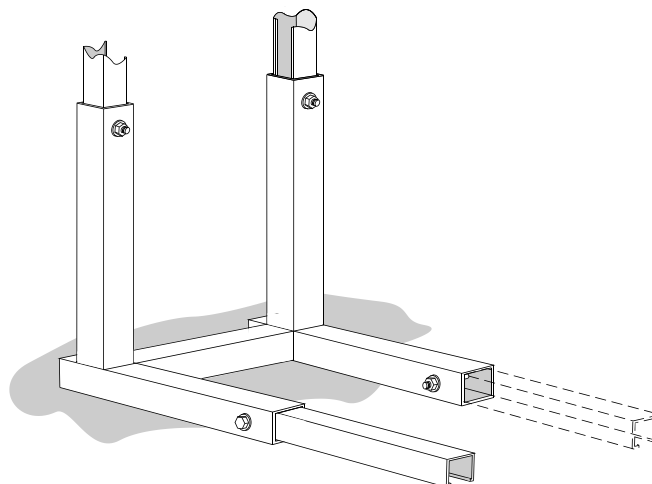

The GAS MASTRRR series GR-2 rail systems are proudly made in the U.S.A. and are backed by a 1 year limited warranty.

THE MASTRRR COMPANY

www.gasmastrrr.com mastrrr@airmail.net
1-800-299-6836 1-800-226-2659 Fax

