

IR-1

INSERTION/RETRACTION ASSEMBLY



INSERTION/RETRACTION ASSEMBLY

The INTRUDRRR series 35F and 35FP are supplied with a PG-1 316 stainless steel flanged packing gland and IR-1 insertion/retraction system for unit installation and removal from the pipeline under pressure/flow conditions. They easily install vertically or horizontally on specified 6" or 8" ANSI flanges.

The Insertion/Retraction assembly utilizes a 2,000 lb. rated split reel worm gear winch to pull the CIU in and out of the packing gland and pipeline. The worm gear design is self braking and holds the CIU in place during operation.

For horizontal installations the assembly is supplied with a floor extension support bracket to insure stable vibration free operation.

All materials of construction are 316 stainless steel including sheave, wire rope, wire rope clamps, bolts, nuts, and washers. Split Reel worm Gear Winch is Black epoxy Coated.

Rear View

Side View

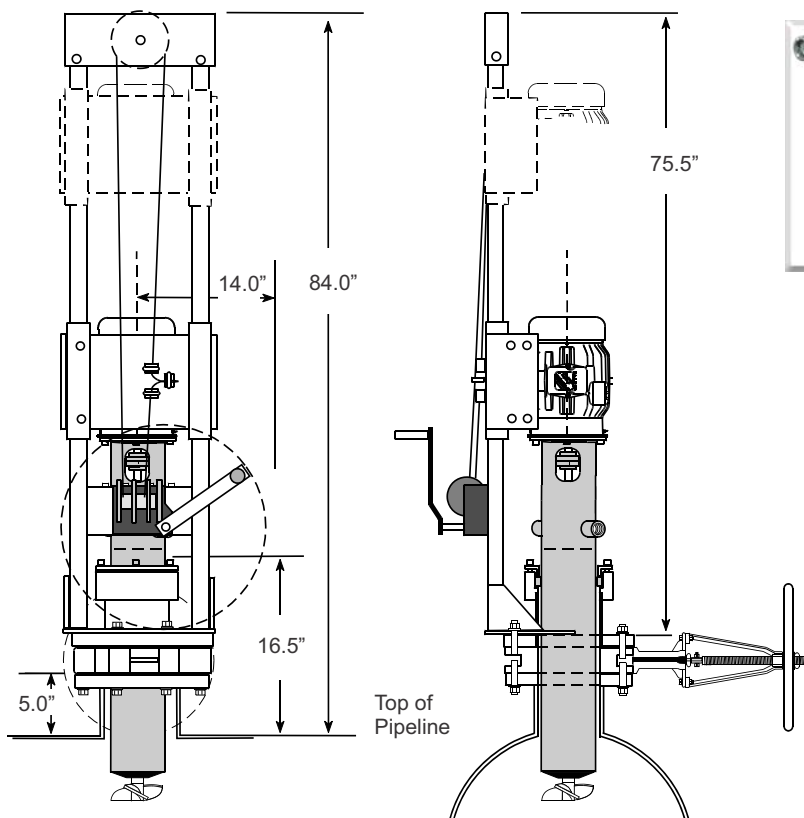

Split Reel Worm Gear Winch

Capacity: 2,000 lbs.

Gear Ratio: 41:1

Black Epoxy Coated

316 Stainless Steel Components

2" Square Tube, Flat Plates, sheave,
1/4" Wire Rope Cable and Clamps,
Bolts, Nuts, & Washers

