

SAVVY 3 "STANDARD" CIU MOTOR MONITORING CONTROL PANEL



SAVVY 3 "STANDARD" CONTROL PANEL

The SAVVY 3 pump motor status monitor and controller panel is designed for use with all GAS MASTRRR series 32 and 32PT submersible units and INTRUDRRR series 35F inline mixers.

The SAVVY 3 panel is Nema 4X rated with a 316 Stainless Steel enclosure for indoor/outdoor service.

Components include a fused disconnect switch, CPT, motor monitor with display, combination starter with adjustable amperage trip heaters, run, off and alarm status lamps, HOA switch, mechanical run time hour meter, and lightning surge arrester. Motor monitoring features include high/low voltage, voltage/current unbalance, phase loss or reversal, over/under current, rapid cycling, and include programmable time delay restarts.

The display keypad supplies realtime data on motor amperage, voltage, % unbalance and data-logging of last four fault conditions. Fault data-logging includes: Date, time, fault condition, amperages, voltages and stop/off/start time.

The panels are wired for three phase service with a variety of voltage options from 200-575 VAC. For series 32XP x-proof motor applications the panels include seal failure moisture detection and high temperature indication and control. Optional audible/visual alarms available. The panels are tested, programmed and ready for service with your CIU.

FEATURES:

- * NEMA 4X 316 Stainless Steel enclosure with clear window and fused disconnect switch for operator safety.
- * High/low voltage, over/under current, phase unbalance or reversal.
- * External motor run-time hour meter (mechanical).
- * Terminal blocks for remote indication and control.
- * Programmable time delay restarts.
- * Data-logging of last four fault conditions with voltage and amperage fault information.
- * Realtime display of amperage and voltage on all legs.



Optional UL Listed quick power cord disconnects and PT-100/SOLO motor high temperature systems.



SYMCOM 777-P2 & RM-2000

MOTOR MONITOR PROGRAMMABLE FUNCTIONS:

- | | |
|---|--|
| 1) Low Voltage Set Point | 13) RS485 Address |
| 2) High Voltage Set Point | 14) No. of restarts after an underload fault |
| 3) Voltage Unbalance Set Point | 15) Underload Trip Delay |
| 4) Amp Range Setting | 16) Ground Fault Trip Point |
| 5) Overcurrent Trip Point | |
| 6) Undercurrent Trip Point | |
| 7) Current Unbalance Trip Point | |
| 8) Trip Class (5, 10, 15, 20, 30) | |
| 9) Rapid Cycle Timer (Rd1) | |
| 10) Overload Restart Delay (Rd2) | |
| 11) Underload Restart Delay (Rd3) | |
| 12) No. of restarts after an overload (Manual or Automatic) | |



SAVVY 3 - CONTROL PANEL - FUNCTIONAL DESCRIPTION



OPERATION

WITH MAIN CIRCUIT BREAKER ON, POWER NORMAL, UNIT SUBMERGED, TURNING H-O-A SWITCH TO HAND STARTS SUBMERSIBLE MOTOR. TURNING H-O-A SWITCH TO AUTO (WITH JUMPER INSTALLED ON TERMINAL BLOCKS #6 & #7 OR REMOTE PLC CONTACT CLOSURE) STARTS SUBMERSIBLE MOTOR.

IN "HAND OR AUTO" POSITION

SHOULD SYMCOM 777-P2 DETECT ABNORMAL

1. HIGH, LOW OR UNBALANCED MOTOR VOLTAGE BEFORE START
2. HIGH, LOW OR UNBALANCED MOTOR AMPERAGE AFTER START
3. PHASE REVERSAL BEFORE START
4. PHASE LOSS BEFORE OR AFTER START
5. RAPID CYCLING
6. GROUND FAULT

CONTACT 777-P2 OR OLS (STARTER OVERLOADS) OPEN, DE-ENERGIZING STARTER, STOPPING CIU MOTOR AND INDICATING ALARM

INDICATION LIGHTS

- OFF INDICATION
- RUN INDICATION
- ALARM INDICATION
- MOTOR RUN TIME TOTAL
- RM-2000 MOTOR INFO
- AUTO-SENSORY STATUS

JOB NAME:	
DESCRIPTION: SAVVY 3 FUNCTIONAL DESCRIPTION	
DATE: 2018	SHEET NO: 1
THE MASTRRR COMPANY WEBSTER, TEXAS (281)-648-8703	FILE NO: SAVVY3-1

SAVVY 3 - CONTROL PANEL DIMENSIONS

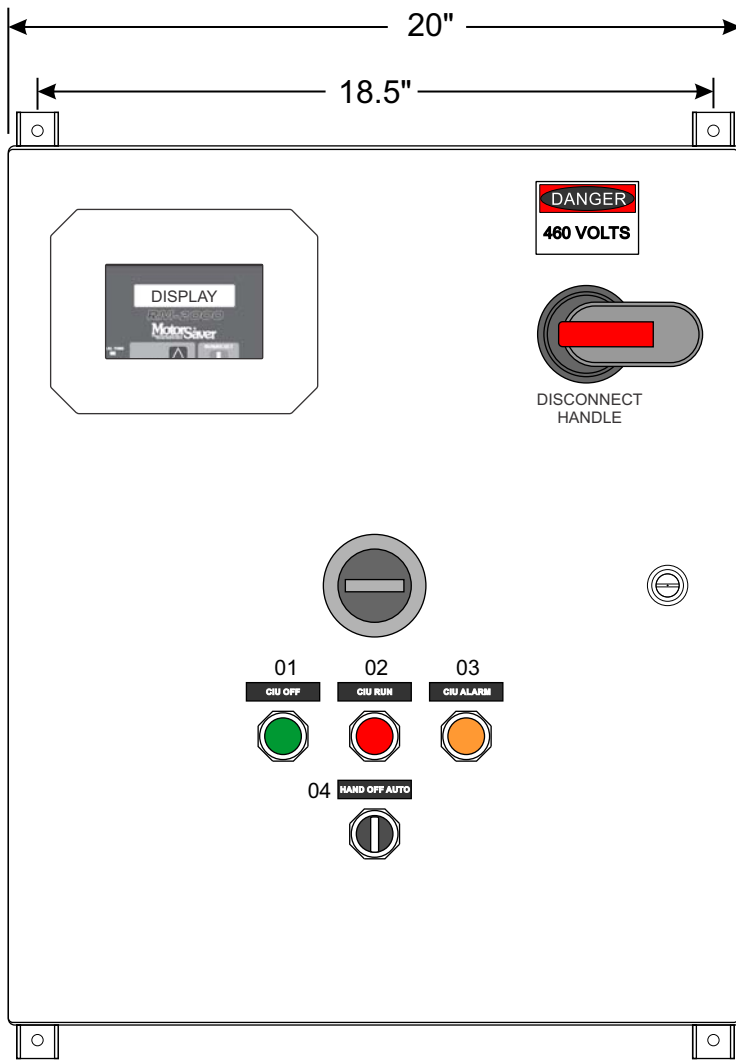

FRONT VIEW

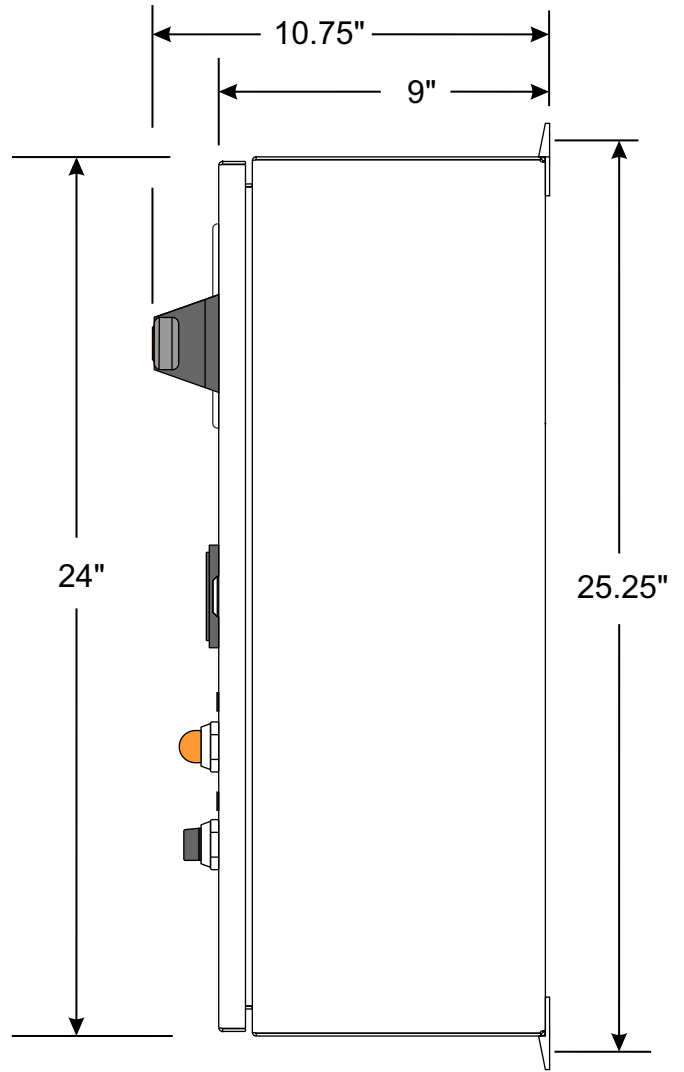

SIDE VIEW

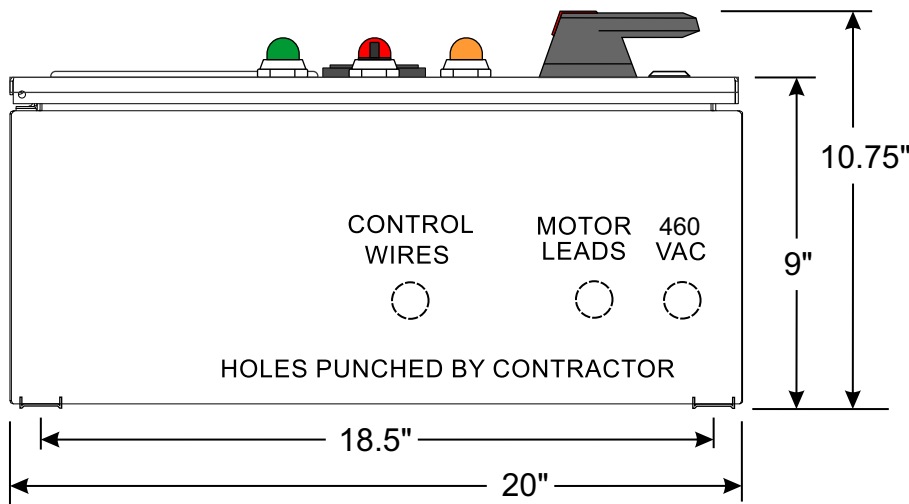

BOTTOM VIEW

LEGEND PLATE SCHEDULE			
TAG	DESC1	DESC2	SIZE
01	CIU	STOPPED	2" X 1/2"
02	CIU	RUN	2" X 1/2"
03	ALARM	FAULT	2" X 1/2"
04	SWITCH	H-O-A	2" X 1/2"

SAVVY 3 PANEL WEIGHT 75 lbs.

JOB NAME:	
DESCRIPTION: SAVVY 3 CONTROL PANEL DIMENSIONS	
DATE: 2018	SHEET NO: 2
THE MASTRRR COMPANY WEBSTER, TEXAS (281)-648-8703	FILE NO: SAVVY 3-1