

SAVVY 4 CIU MOTOR MONITORING CONTROL PANEL



SAVVY 4 CONTROL PANEL

The SAVVY 4 pump motor status monitor and controller panel is designed for use with all GAS MASTRRR series submersible units and INTRUDRRR series inline mixers.

The SAVVY 4 panel is Nema 4X rated with a non-metallic FRP enclosure for indoor/outdoor service.

Components include a fused disconnect switch, CPT, motor monitor with display, combination starter with adjustable amperage trip heaters, run, off and alarm status lamps, HOA switch, mechanical run time hour meter, and lightning surge arrester. Motor monitoring features include high/low voltage, voltage/current unbalance, phase loss or reversal, overcurrent/undercurrent amperage trips, rapid cycling, and include programmable time delay restarts.

The motor monitor provides temperature sensor monitoring in submersible Franklin Electric motors 3 HP and above.

The display keypad supplies realtime data on motor amperage, voltage, % unbalance and data-logging of fault conditions..

The panels are wired for three phase service with a variety of voltage options from 200-575 VAC. For series 32X x-proof motor applications the panels include seal failure moisture detection and high temperature indication and control. Optional audible/visual alarms available. The panels are tested, programmed and ready for service with your CIU.

FEATURES:

- * NEMA 4X FRP enclosure with clear window and fused disconnect switch for operator safety.
- * High/low voltage, over/under current, phase unbalance or reversal, and high temperature protection.
- * External motor run-time hour meter (mechanical).
- * Terminal blocks for remote indication and control.
- * Programmable time delay restarts.
- * Data-logging of last four fault conditions with voltage and amperage fault information.
- * Realtime display of amperage and voltage on all legs..



Optional UL Listed quick power cord disconnects are available for easy installation and removal of the CIU. These quick disconnects are NEMA 4X rated and install at the lower exterior of The SAVVY 4 panel.

MOTOR MONITOR PROGRAMMABLE FUNCTIONS:

1) Low Voltage Set Point	13) RS485 Address
2) High Voltage Set Point	14) No. of restarts after an underload fault
3) Voltage Unbalance Set Point	15) Underload Trip Delay
4) Amp Range Setting	16) Ground Fault Trip Point
5) Overcurrent Trip Point	17) Temperature Sensor Function On/Off
6) Undercurrent Trip Point	
7) Current Unbalance Trip Point	
8) Trip Class (5, 10, 15, 20, 30)	
9) Rapid Cycle Timer (Rd1)	
10) Overload Restart Delay (Rd2)	
11) Underload Restart Delay (Rd3)	
12) No. of restarts after an overload (Manual or Automatic)	

THE MASTRRR COMPANY

www.gasmastrrr.com mastrrr @airmail.net
1-800-299-6836 1-800-226-2659 Fax



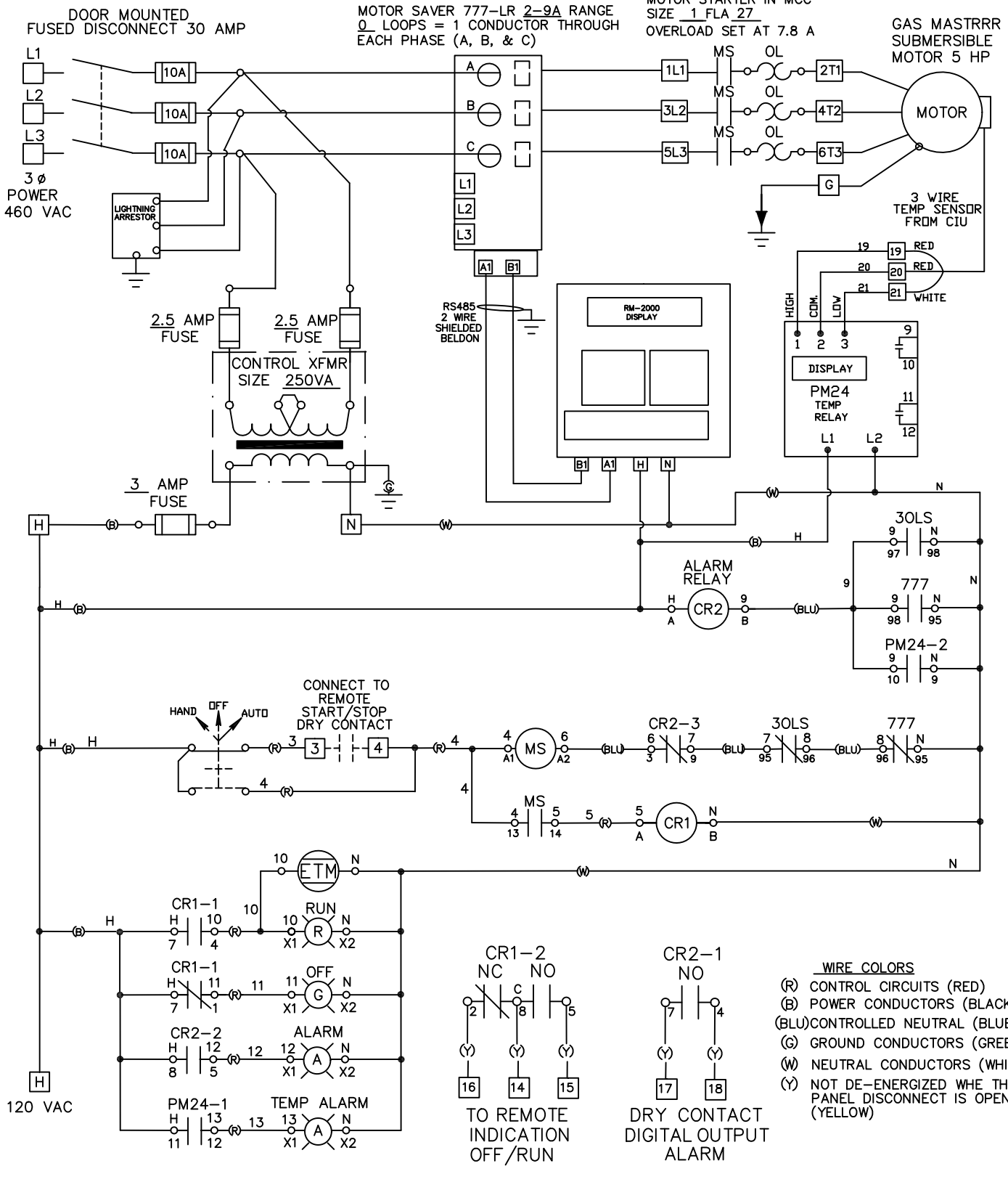

WIRE COLORS
 (R) CONTROL CIRCUITS (RED)
 (B) POWER CONDUCTORS (BLACK)
 (BLU) CONTROLLED NEUTRAL (BLUE)
 (G) GROUND CONDUCTORS (GREEN)
 (W) NEUTRAL CONDUCTORS (WHITE)
 (Y) NOT DE-ENERGIZED WHE THE PANEL DISCONNECT IS OPEN (YELLOW)

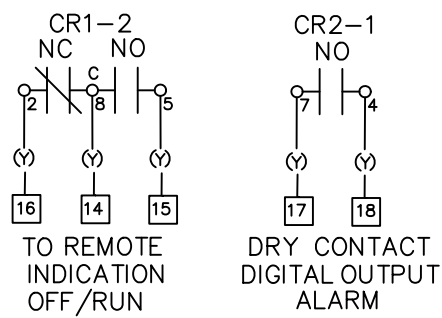

JOB NAME: SAMPLE	
DESCRIPTION: CIU CONTROL PANELS	
DATE: 1-9-09	SHEET NO: 3
THE MASTRRR COMPANY FRIENDSWOOD, TEXAS (800)-299-6836	FILE NO: 1053C

H	3	4	14	15	16	17	18	19	20	21				
---	---	---	----	----	----	----	----	----	----	----	--	--	--	--

TERMINAL BLOCK SCHEDULE
 TORQUE FIELD WIRING
 TERMINAL TO 7.1 INCH Lb.