

INTRUDRRR SERIES 35F FLANGED/IN-LINE CHEMICAL MIXERS



SERIES 35F FLANGED/IN-LINE MIXER

The INTRUDRRR series 35F is a flanged/in-line chemical induction mixer designed for high rate flash mixing of chemicals into pipelines or closed conduits. They easily install vertically or horizontally through 6", 8", or larger ANSI flanges providing superior velocity gradient mixing intensity in 6" and larger pipelines. The series 35F is supplied with a 316 stainless steel packing gland flange & insertion/retraction system for unit installation and removal from the pipeline under pressure/flow conditions.

The standard series 35F is a non-vacuum style liquid chemical feed mixer. The mixer is available in a vacuum style design for vacuum inducing gas or liquid chemicals into low pressured lines below 15 PSI. Standard features include two isolated chemical feed ports for multiple chemical feed applications.

The series 35F utilizes a close coupled rugged and reliable U.S.A. manufactured TEFC severe duty chemical process motor for indoor/outdoor service in corrosive environments.

The INTRUDRRR series 35F is available in 2 - 25 HP for feed rates up to 10,000 PPD gas or 70 GPM liquid chemical per unit.

The INTRUDRRR series 35F utilizes a UHMW Polyethylene mixing element for a high GPM dispersion of the chemical mix in small or large diameter pipelines. Optional 316 stainless steel knife gate valves may be supplied in 6" or larger flange sizes. **NOTE:** 6" concrete lined pipe stubs may require concrete removal to allow barrel to insert smoothly.

Performance Specifications

Model No.	HP	Maximum Gas Induction Cl ₂ (ppd)	Maximum Liquid Induction GPM	Maximum Vacuum (in. Hg)
Series 35F-2	2	500	10	21
Series 35F-3	3	1,500	15	22
Series 35F-5	5	2,000*	20*	22
Series 35F-7.5	7.5	3,500*	25*	23
Series 35F-10	10	6,000*	30*	25
Series 35F-15	15	8,000*	40*	25
Series 35F-20	20	10,000*	50*	26
Series 35F-25	25	10,000*	50*	26

25 HP used for extreme applications where additional mixing intensity is required in large diameter pipelines or long pipe distance between CIU and chemical feed equipment.

*Max gas feed rate & vacuum will vary dependent on chemical feed equipment manufacturers inlet vacuum requirements, supply piping size and length, and the pipeline pressure. A larger HP CIU may be required to pull desired full maximum gas feed range because of these factors. Liquid chemical feed varies with viscosity and other factors, consult factory.

The INTRUDRRR series 35F is proudly made in the U.S.A. and is backed by a 1 year limited warranty. **THE MASTRRR COMPANY** offers an exclusive exchange program for competitive mixers. Contact us for our exchange policy details.



THE MASTRRR COMPANY

www.gasmastrrr.com mastrrr@airmail.net
1-800-299-6836 1-800-226-2659 Fax

INTRUDRRR SERIES 35F FLANGED/IN-LINE CHEMICAL MIXERS



SERIES 35F FLANGED/IN-LINE MIXER SPECIFICATIONS



HP	DIMENSIONS (inches)		C		FEED PORT (inches)
	A	B	6"	8"	
2	62	75.5	26	33	1"
3	65	75.5	26	33	1"
5	65	75.5	26	33	1"
7.5	68	75.5	26	33	1-1/2"
10	68	75.5	N/A	33	1-1/2"
15	72.5	75.5	N/A	33	1-1/2"
20	72.5	75.5	N/A	33	2"
25	73.5	75.5	N/A	33	2"

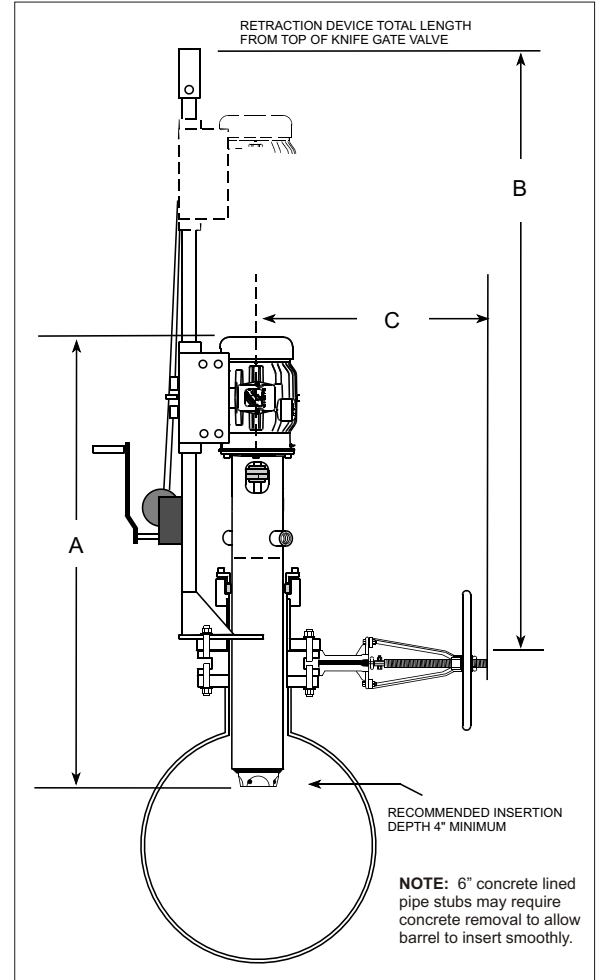

MATERIALS OF CONSTRUCTION

PART	MATERIAL
Motor	Epoxy Coated Cast Iron
Packing Gland	316 Stainless steel
Flange	316 Stainless steel
Barrel	316 Stainless steel
Shaft	Titanium
Cone	UHMW Polyethylene
Mixing Element	UHMW Polyethylene
Feed Port	UHMW Polyethylene

TEFC MOTOR SPECIFICATION DATA VOLTAGE: 230/460 S.F. 1.15

HP	RPM	Amps@460		Frame Size	Nema Design Code	Nominal Power Factor %			Typical Efficiency %		
		FL	LR			F.L.	3/4	1/2	F.L.	3/4	1/2
2	3450	2.5	30	145TC	B	85.0	80.0	70.0	86.5	86.2	83.8
3	3500	3.4	32	182TC	A	92.0	89.0	83.0	88.5	89.1	87.5
5	3500	5.7	62	184TC	A	90.0	86.0	77.0	89.5	89.8	88.2
7.5	3525	8.6	75	213TC	A	90.0	87.0	79.0	91.0	91.4	90.0
10	3500	11.2	120	215TC	B	92.0	89.0	82.0	91.7	92.9	92.7
15	3525	17.2	128	254TC	B	88.0	86.0	78.0	91.7	91.8	90.8
20	3520	22.5	166	256TC	B	90.0	86.0	79.0	92.4	93.0	92.5
25	3430	28	236	284TC	A	91.0	88.0	82.0	93.0	93.5	93.0

The INTDUDRRR series 35F is proudly made in the U.S.A. and is backed by a 1 year limited warranty. THE MASTRRR COMPANY offers an exclusive exchange program for competitive mixers. Contact us for our exchange policy details.

THE MASTRRR COMPANY

www.gasmastrrr.com mastrrr@airmail.net
1-800-299-6836 1-800-226-2659 Fax

